

Inventions (Technology / Know-How)

- **Composition (RCUD) for protecting and/or repairing DNA from oxidative damages and a method thereof**

A composition useful for protecting and/or repairing DNA from oxidative damages has been formed in this invention. This composition is comprised of redistilled cow's urine distillate (RCUD) having components benzoic acid, and hexanoic acid, with ammonia content of the composition ranging between 5-15 mg/L, and optionally along with anti-oxidants. A method of protecting and/or repairing DNA from oxidative damages using this composition has also been developed which involves the steps of estimating the amount of folded DNA in a sample, mixing the said composition to the said DNA either before or after the exposure of the DNA to the oxidatively DNA-damaging agent, and determining percentage folded DNA in the mixture showing protection and/or repair of DNA from oxidative damages.

(Granted China-Patent No. ZL03826375.0 dated 8/4/2009 and US Patent No. 7,718,360 dated 18/5/2010; Inventors: Chakrabarti Tapan, Sivanesan Saravana Devi, Kannan Krishnamurthi, Dutta Dipanwita, Singh Rishi Narain, Mansinghka Sunil Balkrishna and Dawle Suresh Haribhau)

- **Circular secondary clarifier for wastewater treatment and an improved solids-liquid separation process thereof**

The improved circular secondary clarifier as invented by NEERI requires less surface area and low HRT and provides efficient solids-liquid separation. The improved clarifier has better SS and BOD reduction and provides high under flow solids concentrations, as compared to conventional secondary clarifiers. The improved clarifier is even capable of treating wastewaters containing low MLSS concentration. One of the biggest advantages of improved clarifier is that it does not require a separate sump-cum-pump house as it removes the settled sludge using suction mechanism thereby reduces capital and recurring cost. Further, it provides natural flocculation, which is essential for agglomeration of solids and increases particle size referred to as `floc` and eliminates provision for a separate flocculation facility thereby reduces capital and recurring costs.

(Granted US Patent No. 7,637,379, B2 dated 29/12/2009. Inventors: Pophali Girish Ramesh, Nandy Tapas, Kaul Santosh Narain and Devotta, Sukumar)

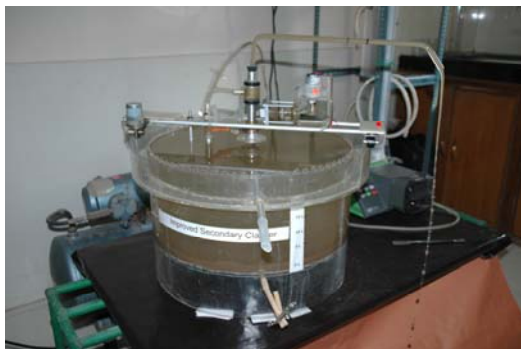

- **An apparatus for decolourization of analytes and a process thereof**

NEERI developed an apparatus for decolourization of analyte and pretreatment process for colour removal from water and wastewater prior to analysis. The invention is based on titanium dioxide and UV light induced oxidation of chromophore bearing compounds which cause interference in analysis of anions by spectrophotometric or turbidimetric method.

(National and international patents have already been filed for this invention. Inventors: Dhodapkar R S, Rao N N and Nandy T)

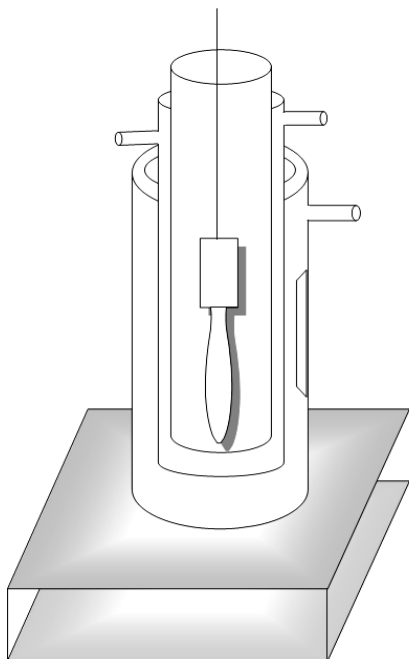

Low volume batch photo reactor used for UV irradiation pretreatment

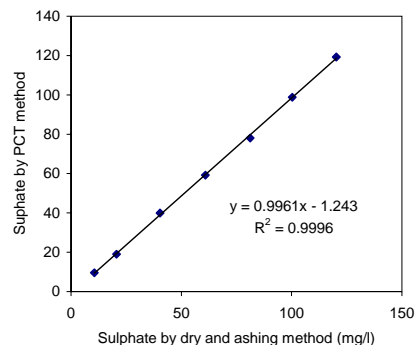

Agreement between sulfate concentrations as determined by the method described in the present invention and drying and ashing method

- **Surface-modified zeolite and process for synthesis thereof for sequestration of anions**

This invention deals with cost-effective surface-modified zeolite materials developed from commercial zeolites and flyash-based zeolites by treating with surface modifiers like hexadecyltrimethyl ammonium bromide (HDTMA-Br). The formation of zeolitic materials with anionic characteristics requires treatment with a surfactant with initial concentrations greater than its critical micelle concentration (CMC). The sorption of oxyanions on the surfactant-modified zeolite (SMZ) is attributed to surface complexation and surface precipitation. Incorporation of metal ions on SMZ showed improved anion uptake for dearsenification of water due to synergistic effects and is able to meet the stringent target of 10 ppb of As on potable water being adopted by most countries. High selectivity, faster kinetics and high adsorption capacity ensures cost effectiveness of this product as compared to other low-cost products for dearsenification. Zeolite analogues with anionic characteristics have been developed for their applications for removal of arsenic from water. The material developed can also be used to remove other anions like chromium and selenium.

(Granted US Patent No. 7510659 dated 31/3/2009. Inventors: Rayalu Sadhana Suresh, Kumar Pawan, Meshram Siddharth Ulhas, Bansiwai Amit Kumar, Labhsetwar; Nitin Kumar, Singh Rishi Narayan and Devotta Sukumar)